

DISCLAIMER  
 The use of this standard is governed by the "Texas Engineering Practice Act". No warranty of any kind is made by TxDOT for any purpose whatsoever. TxDOT assumes no responsibility for the conversion of this standard to other formats or for incorrect results or damages resulting from its use.

1	2	3	4	5	6	7	8	9	10	11	12	13	14	15	16
17	18	19	20	21	22	23	24	25	26	27	28	29	30	31	32
33	34	35	36	37	38	39	40	41	42	43	44	45	46	47	48
49	50	51	52	53	54	55	56	57	58	59	60	61	62	63	

**EXAMPLES OF SIGN SUPPORTS**

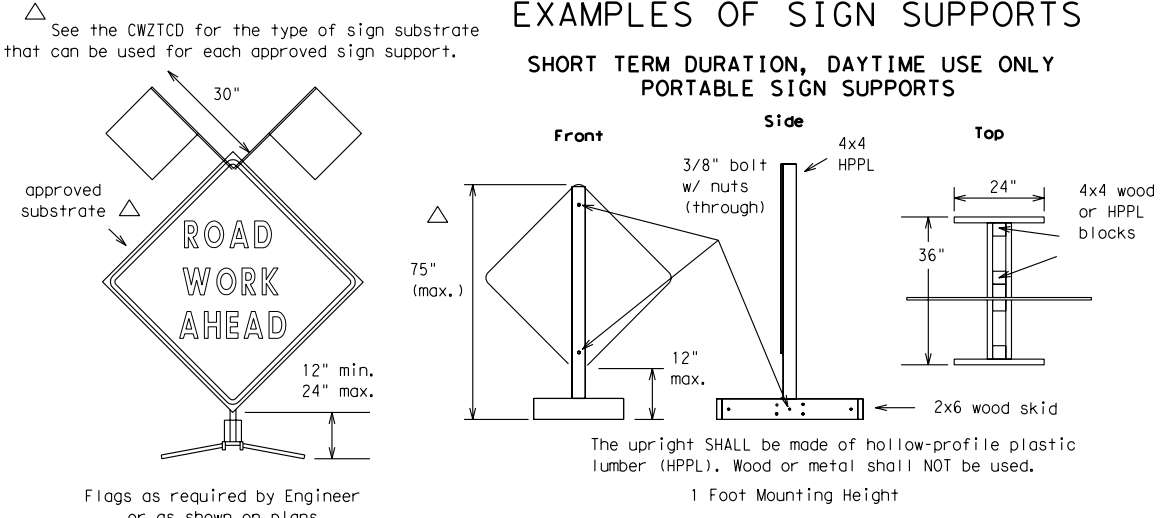

Attachment to wooden supports will be by bolts and nuts or screws. Use TxDOT's or manufacturer's recommended procedures for attaching sign substrates to other types of sign supports.

**Nails will NOT be allowed.**

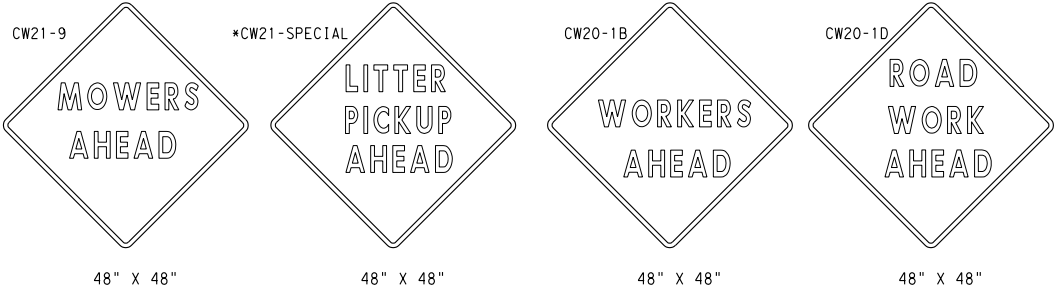

**SIGN IN ACCORDANCE WITH THE TEXAS MANUAL ON UNIFORM TRAFFIC CONTROL DEVICES FOR STREETS AND HIGHWAYS**

**MOWERS AHEAD SIGNS ARE USED FOR MOWING OPERATIONS.**

**LITTER PICKUP AHEAD, ROAD WORK AHEAD AND WORKER AHEAD SIGNS ARE USED AS DIRECTED FOR OTHER MAINTENANCE OPERATIONS WHEN ALL WORK OCCURS OFF OF THE PAVED HIGHWAY SURFACE.**

**ROLL-UP SIGNS CONFORMING TO DMS-8310 AND THE CWZTCO ALLOWED**

\*Letter dimensions and spacing for "CW21-SPECIAL" is the same as C20-1D

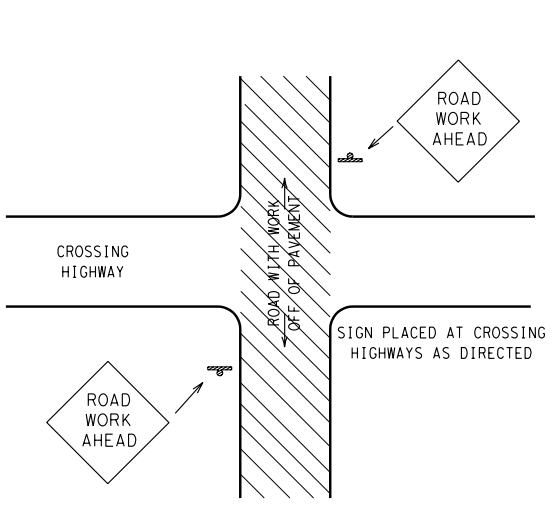

**TYPICAL LOCATION OF SIGNS AT HIGHWAY CROSSING**

WORK AREA IS A MAXIMUM OF 2.0 MILES UNLESS OTHERWISE DIRECTED. SIGNS MAY REMAIN IN PLACE ONLY DURING DAYLIGHT HOURS. SIGNS ARE TO BE PLACED 6' TO 12' OFF OF THE PAVED SURFACE UNLESS OTHERWISE DIRECTED. ROAD WORK AHEAD SIGNS SHOWN AS EXAMPLES, ONE OF THE FOUR TYPE SIGNS WILL BE USED AS DIRECTED.

\* SIGNS IN THE MEDIAN ARE REQUIRED WHEN WORK OCCURS IN MEDIAN

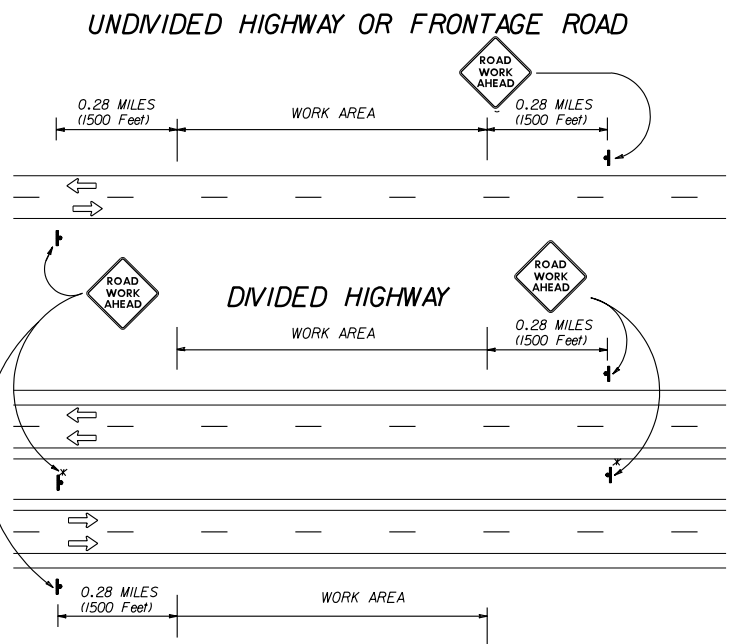

**TRAFFIC CONTROL PLAN FOR WORK OFF OF THE PAVED SURFACE.**

**GENERAL NOTES FOR WORK ZONE SIGNS**

- Contractor shall install and maintain signs in a straight and plumb condition and/or as directed by the Engineer.
- Wooden sign posts shall be painted white.
- Barricades shall NOT be used as sign supports.
- Nails shall NOT be used to attach signs to any support.
- All signs shall be installed in accordance with the plans or as directed by the Engineer. Signs shall be used to regulate, warn, and guide the traveling public safely through the work zone.
- The Contractor may furnish either the sign design shown in the plans or in the "Standard Highway Sign Designs for Texas" (SHSD). The Engineer/Inspector may require the Contractor to furnish other work zone signs that are shown in the TMUTCD but may have been omitted from the plans. Any variation in the plans shall be documented by written agreement between the Engineer and the Contractor's Responsible Person. All changes must be documented in writing before being implemented. This can include documenting the changes in the Inspector's TxDOT diary and having both the Inspector and Contractor initial and date the agreed upon changes. The additional signs requested by the Engineer/Inspector shall not be subsidiary.
- The Contractor shall furnish sign supports listed in the "Compliant Work Zone Traffic Control Device List" (CWZTCO). The Contractor shall install the sign support in accordance with the manufacturer's recommendations. If there is a question regarding installation procedures, the Contractor shall furnish the Engineer a copy of the manufacturer's installation recommendations so that the Engineer can verify the correct procedures are being followed.
- The Contractor is responsible for sign installations and replacing signs with damaged or cracked substrates and/or damaged or marred reflective sheeting as directed by the Engineer/Inspector.
- Identification markings may be shown only on the back of the sign substrate. The maximum height of letters and/or company logos used for identification shall be 1".
- The Contractor shall replace damaged wood posts. New or damaged wood sign posts shall not be spliced.

**Duration of Work (as defined by the "Texas Manual on Uniform Traffic Control Devices" Part VI)**

- The Contractor is responsible for ensuring the sign support and substrate meets crashworthiness. For mowing operation all signs and supports are Short-term Duration for daytime work.
- The Contractor shall furnish the sign sizes shown on this sheet or as directed by the Engineer.

**SIGN SUBSTRATES**

- The Contractor shall ensure that the sign substrate is allowed for the type of sign support that is being used. The CWZTCO lists each substrate that can be used on the different types and models of sign supports.
- "Mesh" type materials are NOT an approved sign substrate.
- All wooden individual sign panels fabricated from 2 or more pieces shall have one or more plywood cleat, 1/2" thick by 6" wide, fastened to the back of the sign and extending fully across the sign. The cleat shall be attached to the back of the sign using wood screws that do not penetrate the face of the sign panel. The screws shall be placed on both sides of the splice and spaced at 6" centers. The Engineer may approve other methods of splicing the sign faces.

**REFLECTIVE SHEETING**

- Reflectorized signs shall be constructed of sheeting meeting the color and retro-reflectivity requirements of DMS-8300 or DMS-8310. The DMS specifications can be accessed from the following web address:  
[http://manuals.dot.state.tx.us:80/dynaweb/colmates/@Generic\\_\\_CollectionView;cs=default;ts=default](http://manuals.dot.state.tx.us:80/dynaweb/colmates/@Generic__CollectionView;cs=default;ts=default)
- White sheeting, meeting the requirements of DMS-8300 Type C (High Specific Intensity), shall be used for signs with white background and channelizing devices.
- Orange sheeting, meeting the requirements of DMS-8300 Type E (Fluorescent Prismatic), shall be used for signs with orange backgrounds.

**SIGN LETTERS**

- All sign letters and numbers shall be clear, and open rounded type uppercase alphabet letters as approved by the Federal Highway Administration (FHWA) and as published in the "Standard Highway Sign Design for Texas" manual. Signs, letters and numbers shall be of first class workmanship in accordance with Department Standards and Specifications.

**REMOVING OR COVERING**

- Signs should be removed or completely covered when not mowing.
- Duct tape or other adhesive material shall NOT be affixed to a sign face.
- Signs and supports shall be removed by the end of the day.

**SIGN SUPPORT WEIGHTS**

- Where sign supports require the use of weights to keep from turning over, the use of sandbags with dry cohesionless sand is recommended.
- The sandbags will be tied shut to keep the sand from spilling and to maintain a constant weight.
- Rock, concrete, iron, steel or other solid objects will not be permitted for use as sign support weights.
- Sandbags should weigh a minimum of 35 lbs and a maximum of 50 lbs.
- Sandbags shall be made of a durable material that tears upon vehicular impact.
- Rubber (such as tire inner tubes) shall NOT be used for sandbags.
- Rubber ballasts (such as those used with cones or edgeline channelizers) shall NOT be used as sign support weights.
- Sandbags shall only be placed along or laid over the base supports of the traffic control device and shall not be suspended above ground level or hung with rope, wire, chains or other fasteners. Sandbags shall be placed along the length of the skids to weigh down the sign supports.
- Sandbags shall NOT be placed under the skid and shall not be used to level sign supports placed on slopes.

**CONTRACTOR REQUIREMENTS FOR MAINTAINING PERMANENT SIGNS WITHIN THE PROJECT LIMITS**

Any sign, sign support or traffic control device that is struck or damaged by the Contractor or his/her construction equipment shall be replaced or repaired as soon as possible by the Contractor at the Contractor's expense.

Only pre-qualified products shall be used. A copy of the "Compliant Work Zone Traffic Control Devices List" (CWZTCO) describes pre-qualified products and their sources and may be obtained by contacting:

Standards Engineer  
 Traffic Operations Division - TE  
 Texas Department of Transportation  
 125 East 11th Street  
 Austin, Texas 78701-2483  
 Phone (512) 416-3120  
 Fax (512) 416-3299

Instructions to locate the "CWZTCO" on TxDOT website are:

Start at website - [www.dot.state.tx.us](http://www.dot.state.tx.us)  
 Click on "About TxDOT",  
 Click on "Organizational Chart",  
 Click on Traffic Operations Box,  
 Click on "Compliant Work Zone Traffic Control Devices",  
 Click on "View PDF".  
 This site is printable.

**Texas Department of Transportation**  
 Maintenance Division  
 Standard Plans

**ROADSIDE TRAFFIC CONTROL PLAN**

SHEET 1 OF 1      RS-TCP-05      NOT TO SCALE

FILE: RSTCP05.DGN	DWG: LJB	CHK: JG	DWG: -	CHK: -	NEG NO.: -
© TxDOT FEBRUARY 2005		STATE DISTRICT	FEDERAL REGION	FEDERAL AID PROJECT	
REVISED: September 17, 2004		N/A	N/A	N/A	
REVISED: FEBRUARY 2, 2005 Sign placement in TCP		COUNTY	CONTROL	SECTION	JOB
REVISED:		N/A	N/A	N/A	N/A